

TRUSS TO TOP PLATE

CONNECTION DETAILS

The minimum fastening requirements for attaching trusses to the top plates of a wall, according to the 2006-2012 International Residential Code (IRC) and International Building Code, require connections that resist 175 pounds of uplift. This condition can be met by installing the MiTek TimberLok as shown below. In many cases where increased wind or seismic loads require a stronger truss to top plate connection, this fastening method may also be used to replace the use of metal ties or straps.

FASTENING METHOD

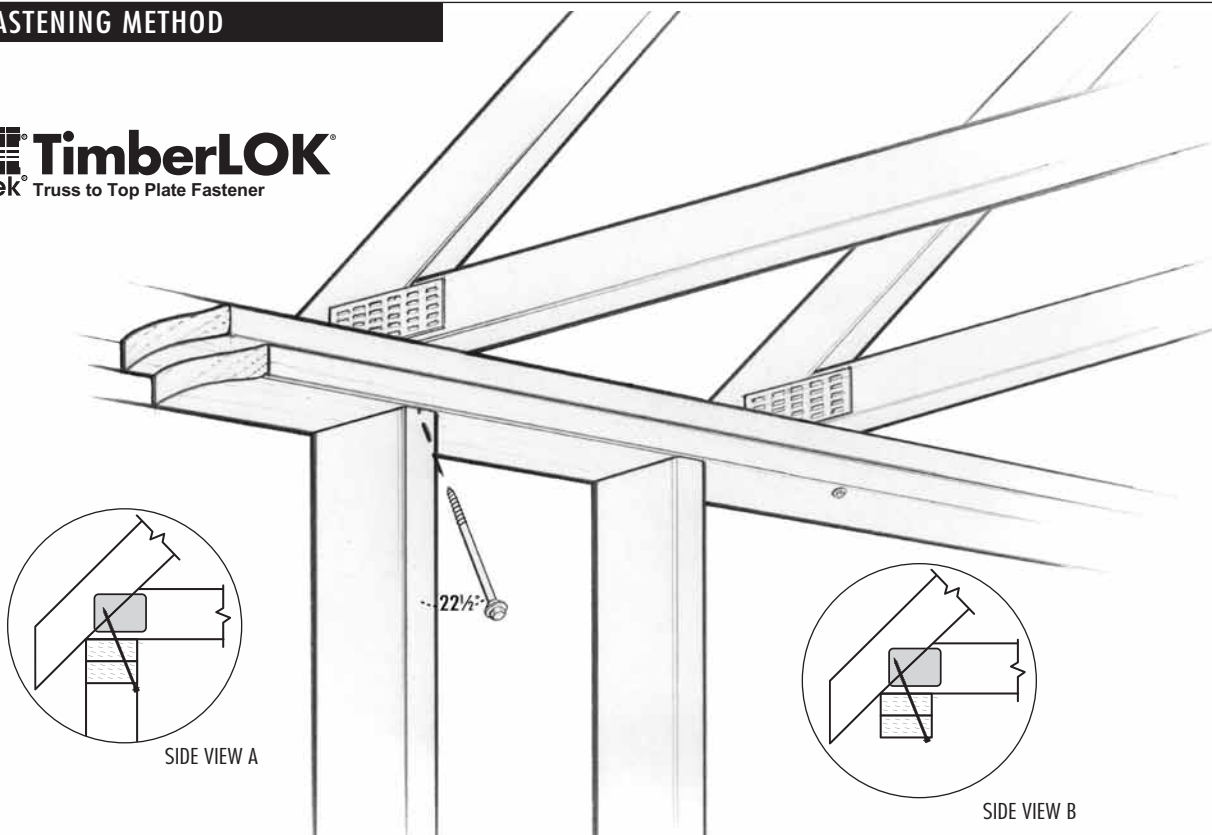

- Use a 6" MiTek TimberLok.
- Where the truss is aligned directly over the wall stud, insert fastener point where the bottom of the top plate and the top of the stud meet (Side View A).
- Where the truss is located between two studs, insert fastener point on bottom surface of the top plate no greater than 1/2" from the inside edge of the plate (Side View B).
- Drive fastener through underside of the top plate at a 22 1/2° angle (+/- 5°) and into the center of the truss.
- Fastener must be driven into the center of the 1 1/2" truss chord edge (+/- 1/4") with the threads fully engaged in the truss chords (bottom chord, top chord or both are acceptable).
- Bring the fastener head flush with the wood surface.



FASTENER DESIGN LOADS

The MiTek TimberLOK load values in Table 1 can be used by a design professional to determine suitability of these fasteners in a truss to top plate connection.

- Where the uplift and/or lateral design loads have been provided on the building plans, the allowable loads in Table 1 can be compared to the plan values to make sure they are met or exceeded by use of this fastening method.
- If ties or straps have been called for to resist uplift and lateral forces, the allowable loads in Table 1 should be compared to the manufacturer's published values for the specified connector to ensure that this fastening method meets or exceeds these loads.
- In cases where the above two methods are not available and the wind speed from IRC Figure 301.2(4) equals or exceeds 100 mph in hurricane-prone regions, or 110 mph elsewhere, the design loads of this connection can be determined by a design professional from one of the following three sources and compared to Table 1:
 1. American Forest and Paper Association (AF&PA) Wood Frame Construction Manual for One- and Two-Family Dwellings (WFCM). A sample of this chart is shown below.
 2. International Code Council (ICC) Standard for the Residential Construction in High Wind Regions (ICC-600).
 3. Minimum Design Loads for Buildings and Other Structures (ASCE-7).

TABLE 1

TimberLOK Design Loads for Truss to Top Plate Connections						
Wood Species	SPF/HF		Douglas Fir		Southern Pine	
Load Type	Uplift	Lateral/Shear	Uplift	Lateral/Shear	Uplift	Lateral/Shear
Allowable Load	420	320	540	380	620	410
<ul style="list-style-type: none"> • TimberLOK values above are based on ICC-ES Report #1078 and independently verified through testing to ASTM D-1761. • A standard wind load duration factor has been applied to these values per NDS Table 2.3.2. Other applicable NDS adjustment factors are at the discretion of a design professional. • These values apply only to the top plate to truss connection and assume that the fastener is properly installed per the instructions on this bulletin. 						

Sample Wind Loads

Table 2 below represents common design wind loads on truss to top plate connections taken from the AF&PA Wood Frame Construction Manual, High Wind Zone Exposure B, Wall Connections at Load Bearing Walls.

TABLE 2

WIND ZONE (MPH)	TRUSS SPACING	Roof Framing Span (ft.)							LATERAL (LB.)	SHEAR (LB.)
		12	16	20	24	28	32	36		
		UPLIFT (lb.)								
90	16" o.c.	82	96	110	125	139	154	168	119	52
90	24" o.c.	123	144	165	187	209	230	252	178	78
100	16" o.c.	124	147	170	193	217	240	264	145	64
100	24" o.c.	186	220	255	290	325	360	396	218	96
110	16" o.c.	170	203	236	269	303	336	370	176	77
110	24" o.c.	255	304	354	404	454	504	554	264	116
120	16" o.c.	220	264	308	352	397	441	486	209	93
120	24" o.c.	331	396	462	528	595	661	728	314	140
130	16" o.c.	275	331	386	442	499	555	611	247	109
130	24" o.c.	413	496	580	664	748	833	917	370	164

This chart is used as an example only and should not be the sole source to design the connection.